

**RERAILING**  
ENTIRE RANGE



<https://jccom.com.ua/>  
[office@jccom.com.ua](mailto:office@jccom.com.ua)  
+38 (063) 243-85-73

**LUKAS**

fast. safe. trusted since 1955.



# Fast and safe **BACK ON TRACK**

LUKAS has been developing and manufacturing exceptional high-pressure hydraulics for industrial use in a wide variety of sectors since as early as 1948. In addition to the industrial and rescue sectors, the rerailling sector completes the portfolio of hydraulic equipment at LUKAS.

For decades, the rerailling systems produced by the Erlangen-based company have been the global leaders. Our highest priority, alongside the quality of the products and a well thought-out portfolio, is precision rerailling and safety when moving loads using a control desk only.

But LUKAS is more than just a producer of hydraulic products – they are also the perfect partner for providing solutions and helping you to get your rail vehicle quickly and safely back on track. Thanks to their years of experience, LUKAS also possesses extraordinary planning expertise and not only delivers the product but also has the perfect solution ready for you.



# One system – ONE SOLUTION

The thoughtfully designed LUKAS rerailling system has been the national and global leader for decades. Benefit from our experience in a wide range of projects all over the world. We have a solution for every problem and will be glad to help you with a customised solution. Invest in true quality and in a product that will help you get derailed vehicles of all kinds back on track quickly and precisely. Use a control desk at a safe distance to move the load along the entire bridge length in both directions with millimetre precision.

This means you can work conveniently and quickly outside the danger area. Get your tracks back in service within a very short time while minimising your down-time expenses.

<b>EXPERTISE AT LUKAS</b>	6
<b>RERAILING SYSTEMS</b>	8
CU CONTROL DESK	10
POWER UNITS	12
TELESCOPIC RAMS	14
SPECIAL JACKS	16
DUO TRAVERSING UNIT	18
RERAILING BRIDGES	20
COMPACT TRAVERSING UNIT	21
<b>EQUIPMENT</b>	22
HIGH-PERFORMANCE HAND PUMPS/ HYDRAULIC HOSES	24
STACKING SETS	25
BASE PLATES/TILT ADAPTER PLATES/ LIFT ROD ADAPTERS	26
TILTING JACKS/ AXLE PUSHER	27
PULLING DEVICE	28
UPRIGHTING SYSTEM	29
DOLLY AUXILIARY CAR	30
<b>eDRAULIC</b>	32
eDRAULIC RESCUE TOOLS	34
<b>EMERGENCY PNEUMATICS</b>	36
S.TEC 12 LIFTING BAGS	38
C.TEC 12 CONNECTABLE BAGS	39

# LUKAS – INNOVATIVE RERAILING TECHNOLOGY

## SMART & SAFE

- + INTUITIVE OPERATION AT A SAFE DISTANCE
- + WELL-DESIGNED TECHNOLOGY COUNTERACTS UNFAVOURABLE LOAD DISTRIBUTIONS
- + EVERY OIL FLOW (LIFTING OR TRAVERSING CYLINDER) IS ASSIGNED A PRESSURE GAUGE
- + OPERATING PRESSURE CAN BE CONSTANTLY MONITORED

## STRONG & FAST

- + INTERNATIONALLY PROVEN PRESSURE OF 530 BAR
- + SMART DUO TRAVERSING SYSTEM
- + MAKES WORK EASY AND SAVES VALUABLE TIME

## COMPACT & LIGHT

- + ALL COMPONENTS ARE VERY COMPACT THANKS TO THEIR HIGH OPERATING PRESSURE AND LIGHTWEIGHT ALUMINIUM DESIGN
- + MORE SPACE IN YOUR RAIL-ROAD VEHICLE
- + TRANSPORT RERAILING EQUIPMENT EASILY AND EFFORTLESSLY

## TOP QUALITY & VERSATILITY

- + RERAILING SYSTEMS ARE DEVELOPED AND PRODUCED IN GERMANY
- + MEET THE HIGHEST QUALITY STANDARDS



**RERAILING SYSTEMS**

**Don't lose a second –  
TAKE CONTROL  
OF THE SITUATION**

LUKAS rerailing systems work with hydraulics, allowing even the heaviest rail vehicles to be effortlessly lifted and laterally shifted. The required oil pressure is generated by a high-quality motor pump. The load can be lifted and lowered and the hydraulic cylinders laterally shifted with precision from the control desk.

Operate our system from a safe distance. Our system counteracts unfavourable load distributions. You will have everything under control.



# CU CONTROL DESK

CU 2DV / CU 4DVV

With the new CU 2DV or CU 4DVV control desk, you can move and rerail derailed vehicles precisely and easily from a safe distance without having to enter the danger area.



CU 2DV

CU 4DVV

## BENEFITS

- Separate oil flows for synchronised lifting
- Precision force control
- User-friendly valve arrangement with automatic spring reset (deadman switch) in case of sudden operator incapacity
- Clearly labelled for ease of use
- Requires little space: collapsible frame
- Foot plates for optimum stability
- Ergonomically positioned handles for easy transport
- Two different lengths of hoses can be attached

	CU 2DV	CU 4DVV
Lift with	2 cylinders simultaneously	4 cylinders simultaneously
Traversing with	1 Duo traversing unit	2 Duo traversing units
Dimensions <sup>1)</sup>	1,030 x 640 x 1,112 mm	1,310 x 640 x 1,112 mm
Weight	43.5 kg	68.0 kg

<sup>1)</sup> LxWxH



# POWER UNITS

The powerful motor pumps in the 650 series supply all of your equipment from the unique LUKAS rerailing system with the power you need for your project. It is possible to work with two or four-flow radial piston pumps. Depending upon your requirements, up to four hydraulic cylinders can be supplied with the same oil flows. Extend and retract identical lifting cylinders synchronously from the control desk.

## BENEFITS

- Separate oil flows for synchronised lifting
- Operating pressure 530 bar/53 MPa
- High operating pressure enables compact cylinder design
- Two working speeds for fast extension without load
- Controlled extension and retraction speeds under load
- Easy transport and space-saving storage

### WITH GASOLINE AND DIESEL MOTORS GC 650-2POWER / GC 650-4POWER / DC 650-4POWER



GC 650-2POWER

GC 650-4POWER

DC 650-4POWER

	GC 650-2POWER	GC 650-4POWER	DC 650-4POWER
Flow capacity low/high pressure	2 x 3.5/1.0 l/min	4 x 2.6/0.7 l/min	4 x 2.6/0.7 l/min
Useable oil quantity	20.0 l	40.0 l	40.0 l
Motor	4-cycle gasoline	4-cycle gasoline	2.5 l diesel
Motor output	4.8 kW	4.7 kW	4.8 kW
Dimensions <sup>1)</sup>	534 x 456 x 612 mm	534 x 456 x 692 mm	674 x 524 x 783 mm
Weight <sup>2)</sup>	78.0 kg	102.0 kg	132.0 kg

<sup>1)</sup> L x W x H <sup>2)</sup> Incl. hydraulic oil

### WITH ELECTRIC MOTOR PC 650-2POWER / PC 650-4POWER



PC 650-2POWER

PC 650-4POWER

	PC 650-2POWER	PC 650-4POWER
Flow capacity low/high pressure	2 x 2.6/0.7 l/min	4 x 2.2/0.6 l/min
Useable oil quantity	23.0 l	40.0 l
Motor	230 V – 50 Hz	400 V – 50 Hz
Motor output	2.2 kW	3.5 kW
Dimensions <sup>1)</sup>	533 x 456 x 612 mm	534 x 456 x 692 mm
Weight <sup>2)</sup>	76.0 kg	99.0 kg



# TELESCOPIC RAMS

HP 10 | T 280 R / HP 16 | T 160 R / HP 25 | T 185 R  
 HP 25 | T 450 R / HP 30 | T 500 R / HP 50 | T 185 R  
 HP 50 | T 400 R / HP 65 | T 400 R / HP 130 | 115 R

LUKAS telescopic and lifting rams are made from a high-strength light metal alloy and are thus particularly lightweight. They are resistant to corrosion and easy to maintain and, thanks to their telescopic design, can manage long piston strokes despite their relatively low height. In addition to their enormous performance, the lifting eyes integrated into their handle bars also make the cylinders easy to transport.

## BENEFITS

- The surfaces of the piston rods are optimally hard-anodised to protect against damage
- Corrugated piston guard plates made from high-strength steel
- The piston strokes and forces of the various cylinders are coordinated with each other in detail



HP 10 | T 280 R



HP 16 | T 160 R



HP 25 | T 185 R

	HP 10   T 280 R	HP 16   T 160 R	HP 25   T 185 R
Piston lifting force 1/2/3	650/301/104 kN	875/416/165 kN	650/301 kN
Piston stroke 1/2/3	90/94/95 mm	50/51/61 mm	90/95 mm
Total stroke	279 mm	162 mm	185 mm
Height	215 mm	169 mm	215 mm
Oil volume	1.4 l	1.1 l	1.3 l
Weight	14.5 kg	15.4 kg	14.6 kg



HP 25 | T 450 R



HP 30 | T 500 R



HP 50 | T 185 R

	HP 25   T 450 R	HP 30   T 500 R	HP 50   T 185 R
Piston lifting force 1/2	650/266 kN	650/301 kN	1,066/504 kN
Piston stroke 1/2	223/228 mm	250/250 mm	89/96 mm
Total stroke	451 mm	500 mm	185 mm
Height	380 mm	465 mm	234 mm
Oil volume	2.8 l	3.25 l	2.0 l
Weight	23.6 kg	28.6 kg	25.2 kg



HP 50 | T 400 R



HP 65 | T 400 R



HP 130 | 115 R

	HP 50   T 400 R	HP 65   T 400 R	HP 130   115 R
Piston lifting force 1/2	1,066/504 kN	1,665/703 kN	1,349 kN
Piston stroke 1/2	195/204 mm	198/201 mm	115 mm
Total stroke	399 mm	399 mm	115 mm
Height	400 mm	400 mm	272 mm
Oil volume	4.3 l	7.0 l	2.9 l
Weight	41.0 kg	61.2 kg	36.7 kg

# SPECIAL JACKS

HP 7 | 360 R / HP 10 | 250 R / HP 21 | 300 R

When it comes to vehicles with low ground clearance, LUKAS special jacks are valuable additions to your rerailing concept. The initial lifting of the vehicle is made easy thanks to the internal jacks. Manufacturers may install bayonet adapters in the vehicle floor depending upon the design and weight of the vehicle. In this case, the LUKAS internal jacks are inserted into the vehicle floor and can be extended there.



HP 7 | 360 R



HP 10 | 250 R



HP 21 | 300 R

## BENEFITS

- Double-acting and can be retracted hydraulically
- Internal jacks are equipped with bayonet fittings
- Three types with different capacities and lifting strokes to choose from

	<b>HP 7   360 R</b>	<b>HP 10   250 R</b>	<b>HP 21   300 R</b>
Piston lifting force 1/2/3	69 kN	100 kN	204 kN
Piston stroke 1/2/3	360 mm	250 mm	300 mm



# DUO TRAVERSING UNIT

**DUO TRAVERSING UNIT / DUO TRAVERSING UNIT, HEAVY LOAD  
ROLLER CARRIAGE / ROLLER CARRIAGE, HEAVY LOAD /  
DISTANCE BARS (SET)**

The LUKAS DUO traversing unit with integrated locking pin allows you to perform the entire operation from a safe distance without manual repositioning, even when working with heavy loads. The DUO traversing unit and roller carriage are equipped with lateral guides to ensure straight movement along the bridge. Integrated sliding plates compensate for vehicle bowing when moving loads. To ensure optimum stability and prevent tilting of the cylinders, LUKAS uses distance bars and roller carriages with smooth roller-bearing-mounted rollers.

## BENEFITS

- Work from the control desk
- Movement in two directions over the entire length of the bridge
- No manual positioning of arresters in the danger area
- Optimises ergonomic body posture
- Integrated sliding plates compensate for the bowing of vehicle
- 90mm bowing without lowering load and repositioning supports
- Roller carriage with slots to insert distance bars and the DUO traversing unit
- Two adjustable distance bars connect the roller carriages and enable safe traversing on the bridge
- Low total system weight



DUO traversing unit/DUO traversing unit, heavy load

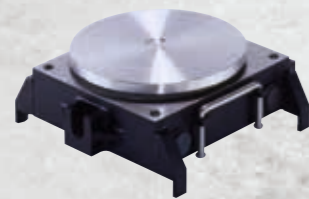

Roller carriage/  
roller carriage, heavy load



DUO traversing unit/  
DUO traversing unit, heavy load



Distance bars (set)

	DUO TRAVERSING UNIT	DUO TRAVERSING UNIT, HEAVY LOAD
Push/pull force	176/92 kN	337/207 kN
Stroke	320 mm	322 mm
Dimensions <sup>1)</sup>	668 × 363 × 197 mm	685 × 370 × 214 mm
Weight	25.0 kg	44.0 kg

<sup>1)</sup> L×W×H

	ROLLER CARRIAGE	ROLLER CARRIAGE, HEAVY LOAD
Permissible load	750 kN	1.000 kN
Height	112 mm	140 mm
Weight	41.6 kg	63.0 kg

	DISTANCE BARS (SET, ADJUSTABLE)	
	Short	Long
Length min./max.	1,030/1,830 mm	1,500/2,800 mm
Weight	40.0 kg	59.0 kg

# RERAILING BRIDGES

85 MM / 140 MM / 184 MM

The rerailing bridge is used as soon as the derailed vehicle has been raised. The vehicle can be moved sideways using either one or two roller carriages (as needed) and the DUO traversing unit, and then lowered onto the rails in the right position.

## BENEFITS

- Rerailing bridges can be connected using connecting elements
- Respond to various track widths
- Three different heights and capacities available



### RERAILING BRIDGES

Length	1.1 m	2.2 m	3.3 m	4.4 m
Width	350 mm	350 mm	350 mm	350 mm
Weight				
85 mm (Low-floor vehicles)	33.0 kg	66.0 kg	98.0 kg	–
140 mm	40.0 kg	81.0 kg	118.0 kg	163.0 kg
184 mm	70.0 kg	140.0 kg	210.0 kg	280.0 kg

### MAXIMUM BRIDGE CAPACITY

Height	85 mm	140 mm	184 mm
Full support	350 kN	1,000 kN	1,200 kN
With 1 m distance between supports	60 kN	500 kN	900 kN
With 1.43 m distance between supports	50 kN	400 kN	650 kN

# COMPACT TRAVERSING UNIT

TRAVERSE DISTANCE UP TO 300 MM

When traversing light rail vehicles on a suitable surface, the compact traversing unit is essential for rerailing quickly and with absolute precision. It can be used with one or two units, depending on the weight of the vehicle.



## BENEFITS

- Easy to transport: compact and light
- Quick change of direction directly on the hand pump
- Movable, Teflon®-coated light metal alloy sliding plates compensate for the bowing of the vehicle
- Minimal frictional resistance thanks to stainless steel sliding surfaces

## FACTS

- For single-point lifting: 200 kN (20 t)  
i.e. rail vehicles weighing up to 400 kN (40 t)
- For two-point lifting: 2 × 150 kN (15 t)  
i.e. rail vehicles weighing up to 600 kN (60 t)

### COMPACT TRAVERSING UNIT

Transverse movement up to	300 mm
Dimensions <sup>1)</sup>	865 × 375 × 153 mm
Weight	73.0 kg

<sup>1)</sup> L × W × H

**EQUIPMENT**

**THE RIGHT SUPPORT**  
for your project

Safety is our number one priority! The LUKAS team has taken this resolution to heart. Consider, for example, how solidly our cylinders stand when rerailing with the help of the appropriate base plates and lifting adapters or stacking sets. From A to Z, from uprighting systems to pulling devices, you will be able to find the support you need amongst our equipment.

Because it is often the small things that contribute to a successful project outcome. We think operations through with you in detail.



# HIGH-PERFORMANCE HAND PUMPS

## ZPH 3/8 – 2 D

Two-stage hand pump for extending telescopic rams. This mobile hand pump allows you to act in an emergency or in environments with a risk of explosion and so you can extend the cylinders by hand. We also recommend the high-performance hand pump for operating the compact traversing unit. This will guarantee a quick, sensitive and precise approach.



### HIGH-PERFORMANCE HAND PUMPS ZPH 3/8 – 2 D

Oil output rate low pressure	10.8cm <sup>3</sup>
Oil output rate high pressure	4.2cm <sup>3</sup>
Capacity of oil reservoir	10.5l
Usable quantity	8.0l
Dimensions <sup>1)</sup>	922 x 259 x 221 mm
Weight	21.0kg

<sup>1)</sup> LxWxH

# HYDRAULIC HOSES

## 10 M / 20 M

Hoses for connecting power units and control desks. Or for jacks and duo traversing cylinders. The hose pair is equipped with safety couplings and is available in two different lengths.



### HYDRAULIC HOSES

10 m hose pair	7 kg
20 m hose pair	11 kg

# STACKING SETS

LUKAS stacking sets increase the maximum lifting height up to 495 mm for extraordinary long strokes.



### STACKING SETS FOR

	HP 10IT 280 R HP 25IT 185 R HP 25IT 450 R HP 30IT 500 R	HP 50IT 185 R	HP 50IT 400 R
Stacking ring, number/height	4/65 mm	4/65 mm	2/150 mm
Piston ring, number/height	3/65 mm + 1/45 mm	3/65 mm + 1/45 mm	1/20 mm + 1/123 mm + 1/150 mm
Fork levers, quantity	1	1	1
Stroke extension max.	240 mm	240 mm	293 mm
Total weight	12.2 kg	21.0 kg	22.2 kg

### STACKING SETS FOR

	HP 65IT 400 R	HP 130IT 115 R
Stacking ring, number/height	3/133.4 mm	1/109 mm + 4/94 mm
Piston ring, number/height	1/20 mm + 2/135 mm + 1/100 mm	5/94 mm
Fork levers, quantity	1	1
Stroke extension max.	390 mm	470 mm
Total weight	42.2 kg	47.0 kg

# BASE PLATES / TILT ADAPTER PLATES / LIFT ROD ADAPTERS

The base plates increase the cylinder's ground area and improve its overall stability, and are thus indispensable for all lifting work. The lifting adapters serve to lift rail vehicles with lift rods with a radius of 40 mm or 80 mm. Tilt adapter plates protect the cylinders against damage and level movements to an angle of 5°.

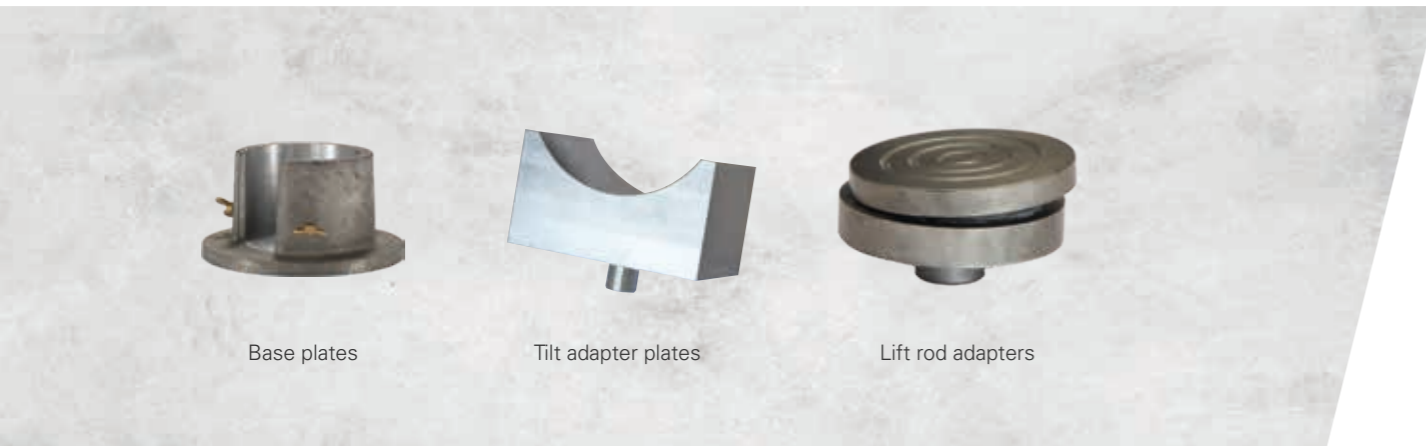

Base plates

Tilt adapter plates

Lift rod adapters

### BASE PLATES FOR

	HP 101 T 280 R	HP 25I T 185 R HP 25I T 450 R	HP 30I T 500 R	HP 50I T 185 R HP 50I T 400 R	HP 65I T 400 R
Weight	7.2 kg	7.2 kg	7.2 kg	9.2 kg	11.0 kg

### TILT ADAPTER PLATES

Load max.	40.0 t
Tilt angle	5°
Weight	1.1 kg

# TILTING JACKS

HP 25 | R 400 R

Some vehicles can be rerailed with a tilting jack, a radius plate and a wheel stop with minimal effort. The diagonal stroke movement simultaneously lifts and traverses the rail vehicle. The wheel stop halts the traversing movement as soon as the wheels are positioned over the rails.



22.0 kg

19.5 kg

7.0 kg

Set with tilting jacks, radius plate and wheel stop, weight 48.5 kg

# AXLE PUSHER

PLUS LFM 10/160 CYLINDER

If the wheels of the vehicle are positioned with the wheel flange on the rails, the axle pusher will push them back into the track. You will also need cylinder LFM 10/160 and the appropriate piston guard plate.



LFM 10/160

Axle pusher

	LFM 10/160	AXLE PUSHER
Stroke	160 mm	-
Lifting force	98 kN	-
Weight	4.2 kg	27.0 kg

# PULLING DEVICE

## PUD 200

Wedged vehicles or obstacles on the line – with the LUKAS pulling device, the vehicle can be put quickly back on track.



### PUD 200

Pulling force	220 kN
Oil volume	1.0l
Weight	194.0kg



# UPRIGHTING SYSTEM

Overturned rail vehicles can be uprighted and railed with ease using the uprighting system.



Claw jacks  
HP50IP850R

Tilting jacks  
HP25IK400R

Radius plate

Sling 3.140m

Holding rope

Shackle

	CLAW JACKS HP 50 P 850 R	TILTING JACKS HP 25 K 400 R	RADIUS PLATE
Pressure	500 kN	266 kN	-
Stroke	850 mm	400 mm	-
Height <sup>1)</sup>	1,150 mm	599 mm	-
Oil volume	6.7l	1.54l	-
Weight	53.0 kg	22.0 kg	7.0 kg
<sup>1)</sup> retracted			

	SLING	HOLDING ROPE	SHACKLE
Permissible load	400 kN	500 kN	250 kN
Length	-	3,000 mm	-
Weight	51.0 kg	15.0 kg	12.8 kg

# DOLLY AUXILIARY CARS

S / M / XL / CUSTOMISED

Blocked or defective rail wheels and wheel sets represent an enormous challenge for rail operators. The LUKAS DOLLY auxiliary car can help you without damaging the rolling stock and rail infrastructure.



	S	M	XL	CUSTOMISED
Scope of use	Metro/light railway vehicles	Main/light railway vehicles	Main line railway vehicles	According to your specifications
Axle load	12.0 – 16.0 t	20.0 t	27.0 t	
Main features	Tool-free mounting	Tool-free mounting	Assembly directly around the defective axle	
Lifting of rail vehicle	ca. 180 mm with rerailling system	ca. 200 mm with rerailling system	ca. 30 mm with rerailling system/self-lifting	
Weight	120.0 – 175.0 kg	195.0 – 225.0 kg	375.0 – 600.0 kg	



**eDRAULIC**

**Compact, more  
performance –  
FASTER TO USE**

LUKAS eDRAULIC technology offers you mobility and flexibility and helps you to rescue people without the need for hose-connected power units. Our eDRAULIC rescue tools allow you to react to any situation quickly. The lack of cumbersome hoses reduces the risk of stumbling at the site of the rescue operation. eDRAULIC rescue tools ensure your mobility even on rough terrain and in narrow spaces. They can be easily manoeuvred even inside the rail vehicle, which makes them very flexible.

Our high-performance batteries will not let you down in your rescue operation. Our compact batteries save space, with no need for connecting the various power units.

LUKAS is the first manufacturer in the world of electro-hydraulic rescue tools and is very proud of its eDRAULIC technology, which is the technology of the future.



# eDRAULIC RESCUE TOOLS

## BENEFITS

- No compromise on performance compared to hose-connected tools
- Work quickly and safely
- Less space required in the vehicle
- Unlimited operating radius
- Star grip for sensitive control of the tool
- Pulls perfectly into position thanks to exceptional blade geometry
- High-performance rescue battery
- “Shark tooth tip” spreader for an aggressive grip
- Cold and heat-resistant housing
- Spreader tip with peeling tip (optional)



S 788 E2 / SP 777 E2



R 421 E2 / SC 757 E2



### S 788 E2

Cutting force up to <sup>1)</sup>	1,101 kN
Round steel up to ø <sup>2)</sup>	42 mm
Blade opening	200 mm
Dimensions <sup>3)</sup>	988 × 266 × 281 mm
Weight <sup>4)</sup>	22.7 kg

<sup>1)</sup> Theoretically <sup>2)</sup> According to EN 13204, NFPA 1936  
<sup>3)</sup> L × W × H <sup>4)</sup> Weight excl. power supply and battery

### SP 777 E2

Spreading force	63 – 600 kN
Spreading distance	813 mm
Squeezing force up to	122 kN
Pulling force	60 kN
Pulling distance	655 mm
Dimensions <sup>1)</sup>	1,080 × 309 × 285 mm
Weight <sup>2)</sup>	23.6 kg

<sup>1)</sup> L × W × H <sup>2)</sup> Excl. power supply and battery

### R 421 E2

Total lift	750 mm
Piston 1 lift	387 mm
Piston 1 lifting force	127 kN
Piston 2 lift	363 mm
Piston 2 lifting force	60 kN
Retracted length	597 mm
Extended length	1,347 mm
Dimensions <sup>1)</sup>	597 × 135 × 313 mm
Weight <sup>2)</sup>	19.0 kg

<sup>1)</sup> L × W × H <sup>2)</sup> Excl. power supply and battery

### SC 757 E2

Cutting force up to	880 kN
Round steel up to ø <sup>1)</sup>	38 mm
Spreading force up to	1,300 kN
Spreading force 25 mm from front end of tips	41 kN
Spreading distance	450 mm
Pulling force up to	98 kN
Pulling distance	297 mm
Dimensions <sup>2)</sup>	1,033 × 294 × 285 mm
Weight <sup>3)</sup>	24.0 kg

<sup>1)</sup> According to EN 13204, NFPA 1936 <sup>2)</sup> L × W × H  
<sup>3)</sup> Excl. power supply and battery

**EMERGENCY PNEUMATICS**

**High-pressure lifting bags –  
SAFETY FOR  
EVERY JOB**

To complete your rerailling concept, please consider the product portfolio of highly specialised emergency pneumatics from our sister company, VETTER GmbH.

The complete range of pneumatics was fully developed and tested by Vetter's own engineers in Germany. As such, their products guarantee you maximum functionality, even under extreme conditions.

VETTER products are TÜV certified, straight forward and easy to use. They perfectly complement the LUKAS rerailling system, especially when there is a limited insertion height at the lifting point.



# S.TEC 12 LIFTING BAGS

12 BAR

As a further development of the mini lifting bags, all models now require an insertion height of just 2.5 cm. With a dynamic 12 bar operating pressure, they can move up to 102 metric tons. Thanks to their intelligent surface structure, two bags can be stacked on top of one another without any danger, and as such even greater extension heights can be reached.

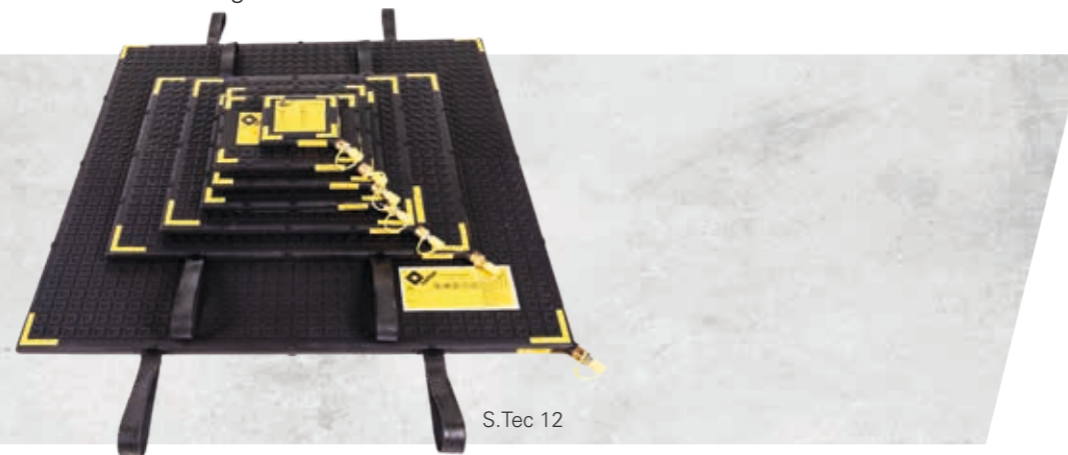

S.Tec 12

	U 1	U 5	U 7	U 10	U 12
Lifting force max. <sup>1)</sup>	1.3t	4.6t	7.5t	10.1t	12.3t
Extension height max.	7.4cm	12.1cm	15.8cm	17.8cm	19.5cm
Dimensions <sup>2)</sup>	14 x 13cm	25.5 x 20cm	28 x 28cm	32 x 32cm	35 x 35cm
Air requirement at 12 bar	4.0l	23.2l	54.0l	120.3l	191.3l
Weight approx.	0.5kg	1.3kg	2.0kg	2.6kg	3.0kg

<sup>1)</sup> Actual lifting force after subtraction of the edge area <sup>2)</sup> L x W

	U 20	U 26	U 33 L	U 35	U 40
Lifting force max. <sup>1)</sup>	20.2t	25.9t	33.3t	34.7t	40.4t
Extension height max.	24.5cm	27.0cm	19.3cm	29.9cm	33.5cm
Dimensions <sup>2)</sup>	44 x 44cm	47 x 52cm	31 x 102cm	52 x 62cm	61 x 61cm
Air requirement at 12 bar	253.0l	279.0l	321.7l	479.0l	603.0l
Weight approx.	4.8kg	6.2kg	8.0kg	8.2kg	9.3kg

<sup>1)</sup> Actual lifting force after subtraction of the edge area <sup>2)</sup> L x W

	U 50	U 59	U 83	U 102
Lifting force max. <sup>1)</sup>	50.1t	59.4t	82.7t	101.6t
Extension height max.	37.5cm	39.3cm	46.6cm	51.6cm
Dimensions <sup>2)</sup>	67.6 x 67.6cm	78 x 69cm	86 x 86cm	95 x 95cm
Air requirement at 12 bar	798.3l	1,103.7l	1,646.0l	2,301.3l
Weight approx.	11.9kg	13.9kg	19.1kg	23.1kg

<sup>1)</sup> Actual lifting force after subtraction of the edge area <sup>2)</sup> L x W

# C.TEC 12 CONNECTABLE BAGS

12 BAR

Vetter C.Tec 12 Connectable Bags combine the lifting force of mini lifting bags and the extension height of the renowned Vetter 1-bar lifting bag. Thanks to their tool-free connection technology, the bags are ready to use in just seconds.



C.Tec 12

	UCB30 C.TEC 12	UCB75 C.TEC 12	UCB172 C.TEC 12
Initial lifting force with full surface contact max. <sup>1)</sup>	30.1t	74.7t	171.8t
Initial lifting force with full contact with load plate max.	14.0t	41.0t	108.0t
Final lifting force max.	7.0t	12.0t	15.0t
Lifting height at final lifting force	21.0cm	35.0cm	59.0cm
Extension height max. <sup>1)</sup>	29.3cm	45.9cm	69.0cm
Air requirement at 12 bar	420.0l	1,476.0l	5,048.0l
Diameter	56.5cm	89.0cm	135.0cm
Weight approx.	18.0kg	34.0kg	58.0kg
Insertion height	9.0cm	9.0cm	11.5cm

<sup>1)</sup> Without load

# THE IDEX FIRE & SAFETY FAMILY is always there for you!



**LUKAS**



**HURST**  
JAWS OF LIFE



**GODIVA**



**Experience technology that gets rail vehicles  
back on track.**

Arrange a consultation appointment.

**LUKAS Hydraulik GmbH**

A Unit of IDEX Corporation  
Weinstraße 39  
91058 Erlangen  
Germany

Fon: +49 9131 698-0  
Fax: +49 9131 698-394  
E-Mail: [lukas.info@idexcorp.com](mailto:lukas.info@idexcorp.com)

[www.lukas.com](http://www.lukas.com)