



nuova**simat**
near to you.



<https://jccom.com.ua/>
office@jccom.com.ua
+38 (063) 243-85-73

BOLTING EQUIPMENT

CATALOGUE



Nuova Simat S.r.l.

Via Spagna, 32-34 | Polo Industriale di Guasticce, 57017, Collesalvetti (LI)
ph. +39 0586 983108 | www.nuovasimat.com | info@nuovasimat.com

BOLTING EQUIPMENT

Catalogue

HYDRAULIC TORQUE WRENCHES	1
SQUARE DRIVE HYDRAULIC TORQUE WRENCHES.....	1
DIRECT ALLEN HEX DRIVE ADAPTER	3
EXTENSION BOOT	4
NON-PUSH-TRHOUGH SQUARE DRIVE	5
FEMALE HEXAGON TORQUE WRENCHES.....	6
MANUAL TORQUE WRENCHES	10
TORQUE MULTIPLIERS	12
PNEUMATIC TORQUE MULTIPLIERS.....	12
BATTERY-POWERED TORQUE MULTIPLIERS	14
ELECTRIC TORQUE MULTIPLIERS	16
ELECTRONICAL TORQUE MULTIPLIERS	17
MANUAL TORQUE MULTIPLIERS.....	19
HYDRAULIC TENSIONERS	20
PST TENSIONERS.....	20
SPECIAL TENSIONERS.....	22
POWERPACKS.....	22
Helios-35.....	24
IMPACT WRENCHES	25
PNEUMATIC IMPACT WRENCHES	25
HYDRAULIC IMPACT WRENCHES.....	25
SOCKETS.....	27
BACK UP WRENCH	28



HYDRAULIC TORQUE WRENCHES

SQUARE DRIVE HYDRAULIC TORQUE WRENCHES



Availability

On Site Service | Sales | Rental

Overview

The NS Series is a dependable workhorse, strong enough to conquer demanding applications with an accuracy +/- 3%. The NS series can handle those ultimate applications where the work subjects' tools to brutal and unforgiving usage. The NS Square Drive Hydraulic Torque Wrench is the wrench you can rely on when the critical work must get done right!

Square Drive

3/4" - 2 1/2"

Torque Range

172 - 78625 Nm

Weight

2.5 - 59.8 kg

Calibration service

Available

DATA SHEET

PART	NS-2	NS-3	NS-5	NS-7	NS-11	NS-20	NS-27	NS-60
Square Drive	3/4"	1"	1 1/2"	1 1/2"	1 1/2"	2 1/2"	2 1/2"	2 1/2"
Minimum Torque (Ft/lbs)	127	330	550	740	1100	1940	2720	5800
Maximum Torque (Ft/lbs)	1270	3300	5500	7400	11010	20625	27200	58000
Minimum Torque (Nm)	172	447	745	1003	1491	2630	3687	7862
Maximum Torque (Nm)	1722	4514	7457	10031	14925	27964	36872	78625
Output Accuracy	+/-3%	+/-3%	+/-3%	+/-3%	+/-3%	+/-3%	+/-3%	+/-3%
Repeatability	100%	100%	100%	100%	100%	100%	100%	100%
Duty Cycle	100%	100%	100%	100%	100%	100%	100%	100%
Tool Weight (lbs)	5.6	10.9	18.1	19.0	29.0	61.0	70.0	130.0
Tool Weight (Kg)	2.5	4.9	8.2	8.6	13.1	27.6	31.7	59.8



DIMENSIONS

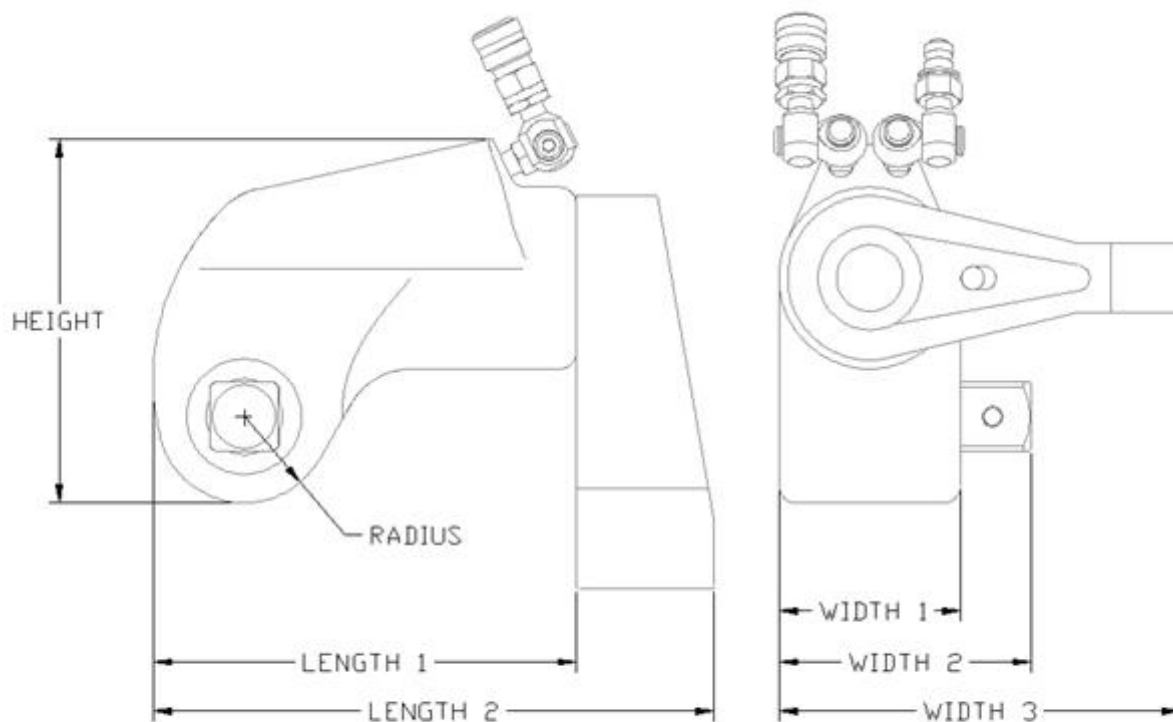

PART	NS-2	NS-3	NS-5	NS-7	NS-11	NS-20	NS-27	NS-60
Height	4.20" / 106.7mm	5.33" / 135.3mm	6.40" / 162.6mm	7.17" / 182.1mm	7.80" / 198.1mm	9.22" / 234.3mm	10.19" / 258.8mm	11.50" / 292.1mm
Length 1	4.82" / 122.4mm	6.40" / 162.5mm	7.91" / 200.9mm	8.84" / 224.5mm	9.79" / 248.6mm	9.44" / 239.7mm	12.32" / 312.9mm	15.38" / 390.7mm
Length 2	6.34" / 161.0mm	8.43" / 214.1mm	10.66" / 270.7mm	11.58" / 294.1mm	12.79" / 324.8mm	16.09" / 408.9mm	16.33" / 414.8mm	20.40" / 518.2mm
Radius	0.98 / 24.9	1.31 / 33.2	1.57 / 39.8	1.77 / 44.9	2.03 / 51.5	2.31 / 58.7	2.46 / 62.5	3.10 / 78.7
Width 1	2.00 / 50.8	2.63 / 66.8	3.12 / 79.2	3.61 / 91.7	3.95 / 100.3	4.87 / 123.6	5.26 / 133.6	6.58 / 167.1
Width 2	2.79 / 70.9	3.68 / 93.5	4.64 / 117.8	5.06 / 128.5	5.43 / 137.9	7.15 / 181.7	7.57 / 192.3	8.89 / 225.8
Width 3	4.42 / 112.3	5.81 / 147.6	7.00 / 177.8	7.98 / 202.7	8.72 / 221.5	10.88 / 276.4	11.63 / 295.4	14.29 / 363.0



ACCESSORIES

DIRECT ALLEN HEX DRIVE ADAPTER



Torque Wrench	Insert Model
NS-0,75	APSD-0,75-11
NS-1	APSD-1-11
NS-2	APSD-2-11
NS-3	APSD-3-11
NS-5	APSD-5-11
NS-7	APSD-7-11
NS-11	APSD-11-11
NS-15	APSD-15-11
NS-20	APSD-20-11
NS-27	APSD-27-11
NS-60	APSD-60-11

DIRECT SOCKET DRIVE



Torque Wrench	Insert Model
NS-0,75	APSD-0,75-11
NS-1	APSD-1-11
NS-2	APSD-2-11
NS-3	APSD-3-11
NS-5	APSD-5-11
NS-7	APSD-7-11
NS-11	APSD-11-11
NS-15	APSD-15-11
NS-20	APSD-20-11
NS-27	APSD-27-11
NS-60	APSD-60-11

EXTENDED REACTION TUBE



Model	Bar model	Diameter	Lenght
NS-0,75	APSD-0,75-03-ERT	1.65	13.77
NS-1	APSD-1-03-ERT	1.65	13.77
NS-2	APSD-2-03-ERT	2	18.57
NS-3	APSD-3-03-ERT	2.63	23.75
NS-5	APSD-5-03-ERT	3	22.5
NS-7	APSD-7-03-ERT	3.5	23
NS-11	APSD-11-03-ERT	3.75	25.1
NS-15	APSD-15-03-ERT	4	22.5
NS-20	APSD-20-03-ERT	4	21.65
NS-27	APSD-27-03-ERT	5	16.5



EXTENSION BOOT



Component	EST.	L	S
APSD-0,75-03-eXt1	1	1.133	0.75
APSD-0,75-03-eXt2	2		
APSD-0,75-03-eXt3	3		
APSD-1-03-eXt1	1	1.133	0.75
APSD-1-03-eXt2	2		
APSD-1-03-eXt3	3		
APSD-2-03-eXt1	1	1.52	1
APSD-2-03-eXt2	2		
APSD-2-03-eXt3	3		
APSD-3-03-eXt1	1	2	1.25
APSD-3-03-eXt2	2		
APSD-3-03-eXt3	3		
APSD-5-03-eXt1	1	2.741	2
APSD-5-03-eXt2	2		
APSD-5-03-eXt3	3		
APSD-7-03-eXt1	1	2.741	1.75
APSD-7-03-eXt2	2		
APSD-7-03-eXt3	3		
APSD-11-03-eXt1	1	3	2
APSD-11-03-eXt2	2		
APSD-11-03-eXt3	3		
APSD-15-03-eXt1	1	3.11	2.32
APSD-15-03-eXt2	2		
APSD-15-03-eXt3	3		
APSD-20-03-eXt1	1	4.17	2.5
APSD-20-03-eXt2	2		
APSD-20-03-eXt3	3		
APSD-27-03-eXt1	1	4	2.5
APSD-27-03-eXt2	2		
APSD-27-03-eXt3	3		
APSD-60-03-eXt1	1	5.11	3.5
APSD-60-03-eXt2	2		
APSD-60-03-eXt3	3		



NON-PUSH-THROUGH SQUARE DRIVE



Torque Wrench	Insert Model
NS-0,75	APSD-0,75-11
NS-1	APSD-1-11
NS-2	APSD-2-11
NS-3	APSD-3-11
NS-5	APSD-5-11
NS-7	APSD-7-11
NS-11	APSD-11-11
NS-15	APSD-15-11
NS-20	APSD-20-11
NS-27	APSD-27-11
NS-60	APSD-60-11



FEMALE HEXAGON TORQUE WRENCHES



Availability

On Site Service | Sales | Rental

Overview

The NSX series is the “go-to” wrench when standard industrial torque tools are limited by size in their ability to engage the fastener. The NSX eliminates issues around the nut, behind the nut and above the nut. On applications with extended stud protrusion, the NSX easily slips over to get the torque applied with an accuracy of +/-3%.

Hexagon Size

1/2” (13mm) – 7 7/8” (200mm)

Torque Range

61 – 64239 Nm

Weight

1 – 30.9 kg

Calibration service

Available

DATA SHEET

PART	NSX-1	NSX-2	NSX-4	NSX-8	NSX-16	NSX-32	NSX-45
Minimum Torque(Ft/lbs)	45	192	395	830	1560	3220	4850
Maximum Torque (Ft/lbs)	560	1928	3950	8630	16600	35650	47380
Minimum Torque (Nm)	61	260	535	1125	2155	4365	6575
Maximum Torque (Nm)	759	2614	5355	11699	22503	48327	64239
Output Accuracy	+/-3%	+/-3%	+/-3%	+/-3%	+/-3%	+/-3%	+/-3%
Repeatability	100%	100%	100%	100%	100%	100%	100%
Duty Cycle	100%	100%	100%	100%	100%	100%	100%
Cylinder Weight (lbs)	1.00	3.50	6.00	11.70	16.00	26.00	29.00
Cylinder Weight (Kg)	0.5	1.6	2.7	5.0	7.3	11.5	13.0
Link Weight From (lbs)	1.0	2.4	5.4	11.9	21.0	29.0	29.0
Link Weight To (lbs)	1.0	3.5	7.6	14.5	28.0	39.5	39.5
Link Weight From (Kg)	0.45	1.0	2.4	5.5	9.5	13.0	13.0
Link Weight To (Kg)	0.45	1.5	3.4	6.5	13.0	17.9	17.9
Hex Range From	1/2" / 13mm	3/4" / 19mm	1" / 27mm	1 7/8" / 49mm	2 3/16" / 55mm	3 1/8" / 80mm	3 1/8" / 80mm



PART	NSX-1	NSX-2	NSX-4	NSX-8	NSX-16	NSX-32	NSX-45
Hex Range To	2" / 50mm	2 9/16" / 65mm	3 1/8" / 80mm	4 5/8" / 120mm	5 5/16" / 135mm	7 7/8" / 200mm	7 7/8" / 200mm

DIMENSIONS

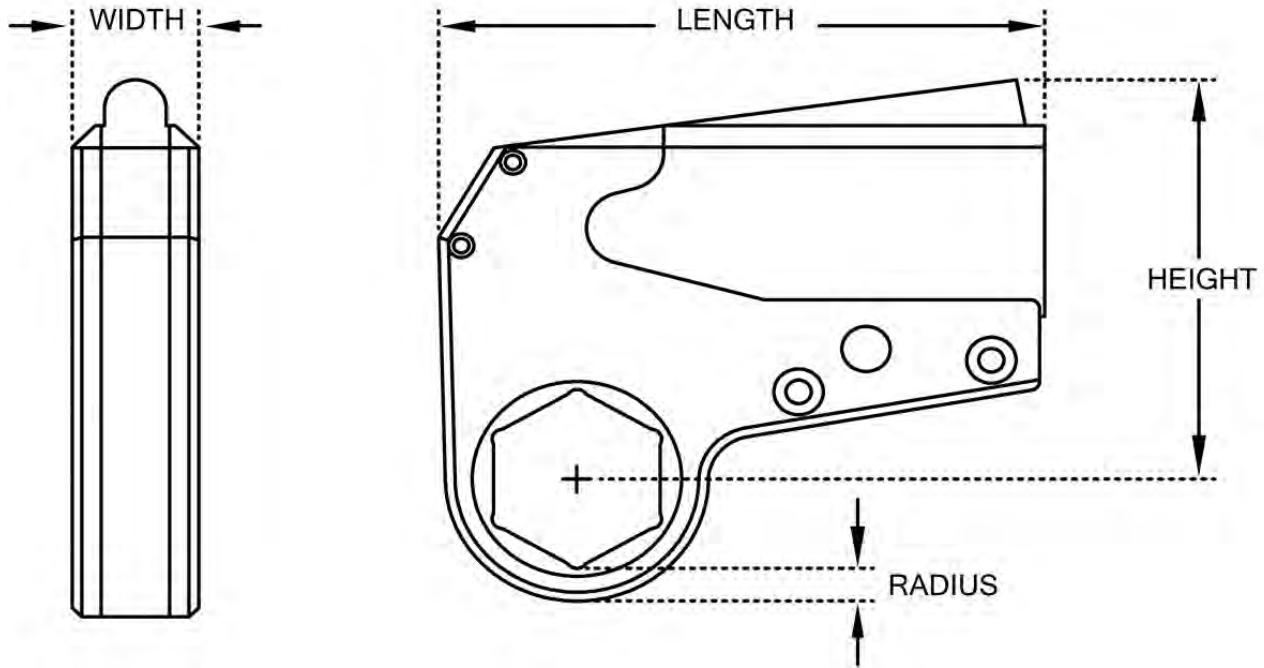

PART	NSX-1	NSX-2	NSX-4	NSX-8	NSX-16	NSX-32	NSX-45
Length	4.37" / 111.0mm	6.45" / 163.8mm	7.87" / 199.9mm	10.18" / 258.6mm	12.93" / 328.4mm	15.8" / 401.3mm	16.75" / 425.5mm
Width	0.78" / 19.8mm	1.25" / 31.8mm	1.63" / 41.4mm	2.05" / 52.1mm	2.50" / 63.5mm	3.24" / 82.3mm	4.88" / 124.0mm
Radius Range From (in/mm)	0.24" / 6.2mm	0.37" / 9.6mm	0.41" / 10.5mm	0.56" / 14.2mm	0.68" / 17.1mm	0.96" / 24.3mm	0.96" / 24.3mm
Radius Range To (in/mm)	0.45" / 11.4mm	0.59" / 15.0mm	0.77" / 18.7mm	0.93" / 21.0mm	1.68" / 25.9mm	1.82" / 44.2mm	1.82" / 44.2mm
Height	3.25" / 82.6mm	4.00" / 101.6mm	5.60" / 142.2mm	7.00" / 177.8mm	7.58" / 192.5mm	9.50" / 241.3mm	10.28" / 261.1mm



ACCESSORIES

HEX-TO-SQUARE DRIVE ADAPTOR



Torque Wrench	Insert Model
NSX-0,75	AHS0,75
NSX-1	AHS1
NSX-2	AHS1,5
NSX-3	AHS2
NSX-5	AHS4
NSX-7	AHS8
NSX-11	AHS16
NSX-15	AHS32
NSX-20	AHS45

EXTENDED REACTION ARM



Torque Wrench	Insert Model	L	H	S
NSX-0,75	NSX-0,75-EXT	13,5	1,25	1,25
NSX-1	NSX-1-EXT	13,5	1,25	1,25
NSX-1,5	NSX-1,5-EXT	13,5	1,25	1,15
NSX-2	NSX-2-EXT	19,8	1,54	1,9
NSX-4	NSX-4-EXT	20,29	2,4	2,4
NSX-8	NSX-8-EXT	20,85	2,52	3,03
NSX-16	NSX-16-EXT	21,5	3,04	3,65
NSX-32	NSX-32-EXT	22,28	3,95	4,52
NSX-0,75	NSX-0,75-EXT	13,5	1,25	1,25

HEX REDUCER



Torque Wrench	Insert Model
NSX-0,75	HR-0,75-#-#
NSX-1	HR-1-#-#
NSX-2	HR-1,5-#-#
NSX-3	HR-2-#-#
NSX-5	HR-4-#-#
NSX-7	HR-8-#-#
NSX-11	HR-16-#-#
NSX-15	HR-32-#-#
NSX-20	HR-45-#-#



LOW POINT REACTION PADDLE



MODEL	BAR MODEL	DIAMETER	LENGHT
NSX-0,75	NSX-0,75-RP	2,73	0,65
NSX-1	NSX-1-RP	2,73	0,65
NSX-1,5	NSX-1,5-RP	2,73	0,65
NSX-2	NSX-2-RP	4,35	1,03
NSX-4	NSX-4-RP	5,65	1,23
NSX-8	NSX-8-RP	7,15	1,78
NSX-16	NSX-16-RP	9,05	2,51
NSX-32	NSX-32-RP	11,2	3,26
NSX-45	NSX-45-RP	11,2	3,26
NSX-0,75	NSX-0,75-RP	2,73	0,65

HYDRAULIC TORQUE WRENCH PUMPS



ELECTRIC PUMP



PNEUMATIC PUMP



MANUAL TORQUE WRENCHES



Availability

On Site Service | Sales | Rental

Overview

Manual torque wrenches are reliable and accurate tools, mastering every conceivable nut tightening operation in all areas of industry. These manual dynamometric torque wrenches cover a wide range of bolting applications from 2,5 to 2700 Nm.

Square Drive

3/8" - 1"

Torque Range

2,5 - 2000 Nm

Weigh

0,56 - 18 kg

Calibration service

Available

DATA SHEET

MODEL	CAPACITY				DRIVE	STEP	LENGHT	WEIGHT
	N-m	Kgfm	Lbf.ft	Lbf.in				
1001	2,5-11	0,3-1,2	2-8	20-100	3/8"	0,5	300	0,56
1001CR	2,5-11	0,3-1,2	2-8	20-100	3/8"	0,5	300	0,62
1003	5-33	0,5-3,4	4-24	40-300	3/8"	1	405	0,69
1003CR	5-33	0,5-3,4	4-24	40-300	3/8"	1	410	0,75
1006S	12-68	1,2-7	10-50	100-600	3/8"	2	480	1
1006	12-68	1,2-7	10-50	100-600	1/2"	2	480	1
1015	25-150	2,5-15	20-110	200-1300	1/2"	5	575	1,7
1025	50-250	5-25	40-180	450-2200	1/2"	10	605	2,3
1040	70-350	7-35	50-260	600-3100	1/2"	10	815	3
1040S	100-400	10-40	70-300	800-3500	3/4"	10	700	3,85
1060	100-600	10-60	60-440	800-5200	3/4"	20	870	5,5
1080	140-800	14-80	120-580	1400-7000	3/4"	20	935	6,5
1100	200-1000	20-100	150-750	1500-8500	1"	25	1030	9,7
0200	500-2000	50-200	350-1500	14500-17500	1"	50	1400	18



ACCESSORIES



Kit of 31 pcs:

Torque wrench mod.930F
(60 – 350 N·m)

Ratchet with 1/2" square drive

Sockets 12-13-14-15-16-17-18-19-21-22-
23-24-26-27-28-30-32

Open end heads 17-19-22-24-27-30-32

Bits holder for hexagon bits

Hex bits 5-6-8-10



TORQUE MULTIPLIERS

PNEUMATIC TORQUE MULTIPLIERS



Availability

On Site Service | Sales | Rental

Overview

The RP series handle makes it appear like an impact wrench, but once you pull the trigger nothing about this tool relates to the word "IMPACT". This is a smooth-running instrument for applying vast amounts of torque in a continuous fluid like manner. Every application is met with repeatable torque to an accuracy of +/-5%.

Square Drive

3/4" - 1 1/2"

Torque Range

106 - 8121 Nm

Weigh

4.1 - 16.3 kg

Calibration service

Available

DATA SHEET

MODEL	RP 500	RP 1000	RP 2000	RP 3000	RP 6000
Square Drive	3/4"	1"	1"	1"	1 1/2"
Min. Torque (Ft/Lbs)	78	148	231	484	714
Max. Torque (Ft/Lbs)	530	1030	2015	3070	6000
Min. Torque (Nm)	106	201	313	656	968
Max. Torque (Nm)	719	1396	2732	4162	8121
Output Accuracy @ Set Torque	+/- 5%	+/- 5%	+/- 5%	+/- 5%	+/- 5%
Repeatability	100%	100%	100%	100%	100%
Duty Cycle	100%	100%	100%	100%	100%
Weight w/o Arm	9lbs/4.1kg	12lbs/5.4kg	16lbs/7.3kg	20lbs/9.1kg	36lbs/16.3kg
RPM @ 10 psi	16.5	7	3.5	1.75	1.25
Tool Max psi	80 psi	70 psi	90 psi	65 psi	90 psi
RPM @ Max psi	44	15	9	4	3
Requirements	Air pressure 10-90 psi / Flow 45-55 CFM				



DIMENSIONS

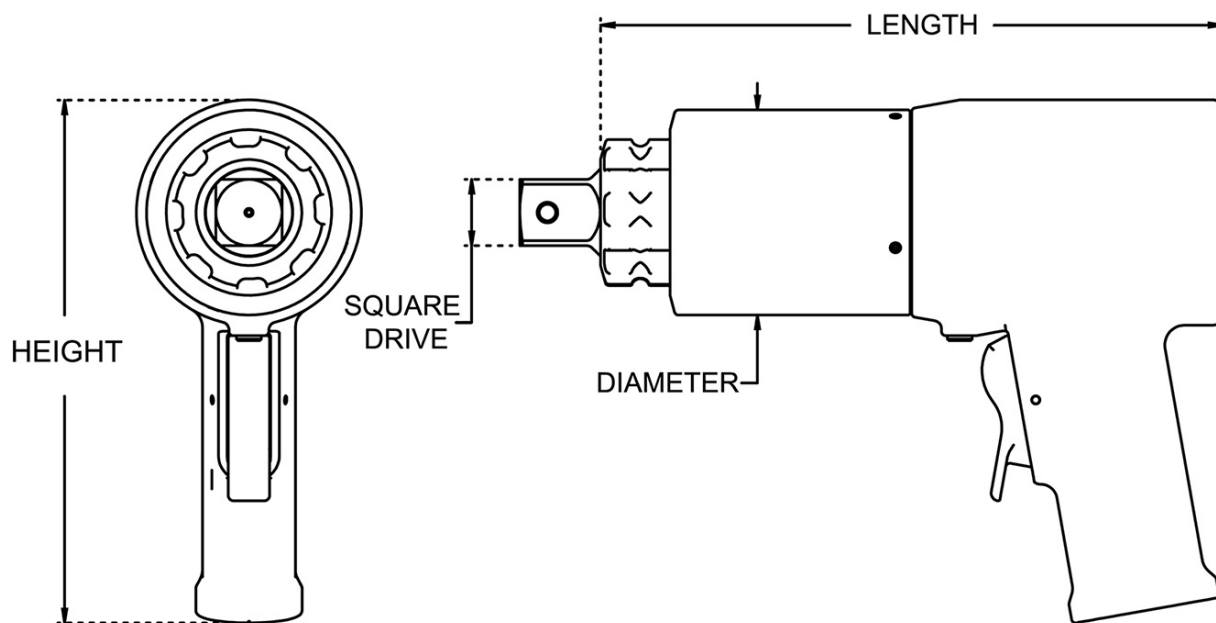

MODEL	RP 500	RP 1000	RP 2000	RP 3000	RP 6000
Height	7.89" / 200.4mm	7.89" / 200.4mm	7.89" / 200.4mm	8.06" / 204.7mm	8.69" / 220.7mm
Square Drive	0.75" / 19.05mm	1.00" / 25.4mm	1.00" / 25.4mm	1.00" / 25.4mm	1.50" / 38.1mm
Length	6.80" / 172.7mm	8.87" / 225.3mm	9.40" / 238.8mm	11.62" / 295.2mm	12.32" / 312.9mm
Diameter	2.56" / 65mm	2.85" / 72.4mm	3.09" / 78.5mm	3.75" / 95.3mm	5.00" / 127.0mm

ACCESSORIES



BATTERY-POWERED TORQUE MULTIPLIERS



Availability

On Site Service | Sales | Rental

Overview

With the introduction of the VT Series, your ability to torque industrial fasteners has now become as simple as a quick charge away with the first ever battery powered torque wrench. The VOLTA has been engineered to master any application effortlessly. Fully charged in under 60 minutes, the VOLTA's lithium battery provides enough power to take on hundreds of fastenings with no hoses or cords to limit your reach.

Square Drive

3/4" - 1"

Torque Range

160 - 4030 Nm

Weight

3.8 - 8.9 kg

Calibration service

Available

DATA SHEET

MODEL	VT 500	VT 1000	VT 2000	VT 3000
Square Drive	3/4"	1"	1"	1"
Min. Torque (Ft/Lbs)	120	240	500	750
Max. Torque (Ft/Lbs)	500	1000	2000	3000
Min. Torque (Nm)	160	330	680	1020
Max. Torque (Nm)	670	1350	2710	4030
Weight w/o Arm & Battery	8.3lbs/3.8kg	11.5lbs/5.2kg	13.1lbs/5.9kg	19.6lbs/8.9kg
Weight w/ Arm & Battery	10.4lbs/4.7kg	14.5lbs/6.6kg	15.9lbs/7.2kg	22.5lbs/10.2kg
RPM @ Min. Torque	12	2	1	0.5
RPM @Max Torque	20	8	5	2

Requirements

Charger Requirements: 110 - 120 V (50-60 Hz)
and 230 - 240 V (50-60 Hz)



DIMENSIONS

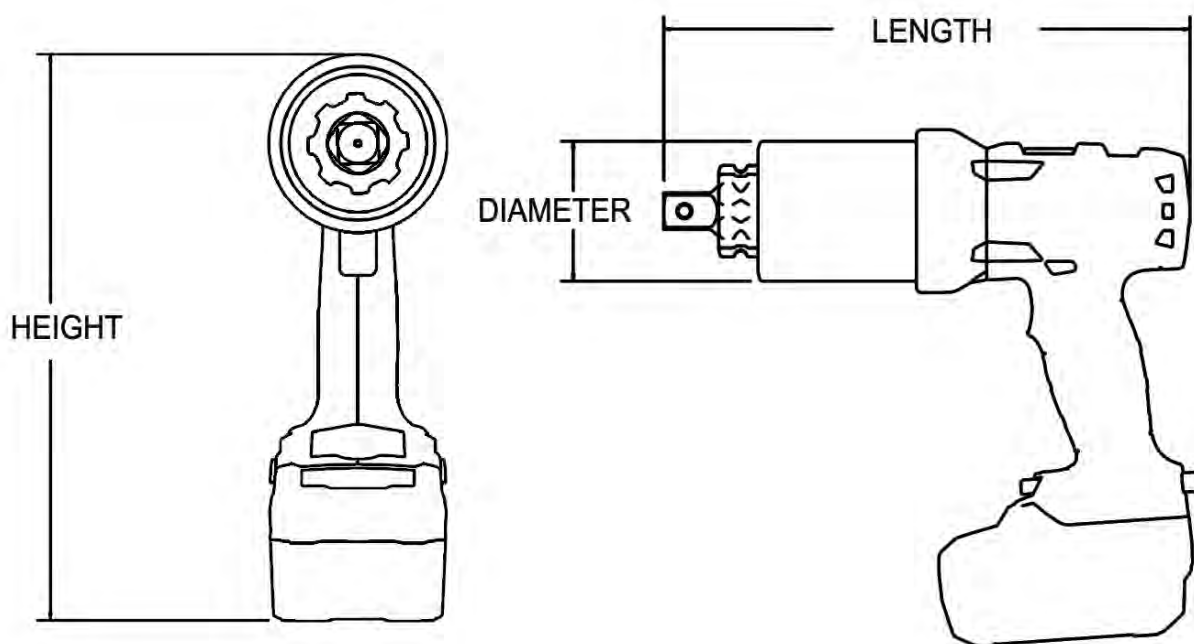

MODEL	VT 500	VT 1000	VT 2000	VT 3000
Square Drive	0.75" / 19.05mm	1.00" / 25.4mm	1.00" / 25.4mm	1.00" / 25.4mm
Length	8.86" / 225.0mm	10.97" / 278.6mm	11.45" / 290.8mm	13.94" / 354.1mm
Height	10.40" / 264.2mm	10.40" / 264.2mm	10.40" / 264.2mm	10.40" / 264.2mm
Diameter	2.56" / 65.0mm	2.85" / 72.4mm	3.09" / 78.5mm	3.75" / 95.3mm

ACCESSORIES

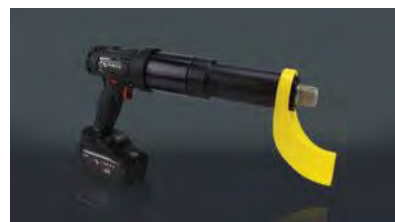

ELECTRIC TORQUE MULTIPLIERS



Availability

On Site Service | Sales | Rental

Overview

Electric torque multipliers in standard (straight) or angled version, with power supply from 220-240V AC, 50 / 60Hz. Torque control on LCD digital display and automatic switch-off function when the set tightening value is reached.

Several models are available covering a range from 80 to 12000 Nm.

Calibration Service

Available

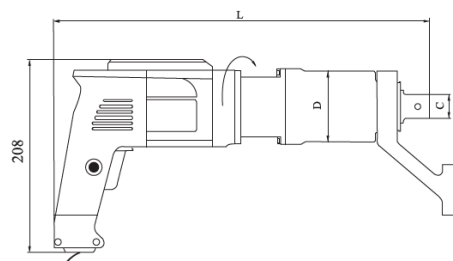

DATA SHEET

MODEL	TORQUE <i>Nm</i>	SQUARE C <i>inches</i>	DIAMETER D <i>mm</i>	LENGTH L <i>mm</i>	FREE SPEED <i>rpm</i>	WEIGHT <i>kg</i>
ESW-04	80-450	3/4"	76	395	21.0	5.4
ESW-08	100-850	3/4"	76	395	12.0	5.4
ESW-12	200-1200	1"	76	400	9.0	5.4



ELECTRONICAL TORQUE MULTIPLIERS



Availability

On Site Service | Sales | Rental

Overview

Through the use of integrated encoders both torque and torque plus angle control are available at the touch of the screen. Angle control is available in both tighten and loosen directions for a total solution to your engineered specifications.

Square Drive

3/4" - 1 1/2"

Torque Range

136 - 8135 Nm

Calibration Service

Available

DATA SHEET

MODEL NUMBER	SR-500	SR-1000	SR-2000	SR-3000	SR-6000	MODEL NUMBER
Square Drive	3/4"	1"	1"	1"	1 1/2"	Square Drive
Min Torque (ft/lbs)	100	200	400	600	1200	Min Torque (ft/lbs)
Max Torque (ft/lbs)	500	1000	2000	3000	6000	Max Torque (ft/lbs)
Min Torque (nm)	136	271	542	813	1627	Min Torque (nm)
Max Torque (nm)	678	1356	2712	4067	8135	Max Torque (nm)
Output Accuracy at set torque	+/- 3%	+/- 3%	+/- 3%	+/- 3%	+/- 3%	Output Accuracy at set torque
Repeatability	100%	100%	100%	100%	100%	Repeatability
Duty Cycle	100%	100%	100%	100%	100%	Duty Cycle
Tool Weight w/o reaction arm	10.9lbs / 4.9kg	14lbs / 6.4kg	15.6lbs / 7.1kg	22.3lbs / 10.1kg	38.3lbs / 17.4kg	Tool Weight w/o reaction arm
Standard Reaction Arm	2.05lbs / 0.93kg		2.85lbs / 1.29kg		2.85lbs / 1.29kg	
RPM @ min torque	2.6		2		3	
RPM @ max torque	25		10		6	
Control Box	20.0lbs / 9.07kg					
Power Cable	1.65lbs / .75kg					
Data Cable	5.3lbs / 2.4kg					



DIMENSIONS

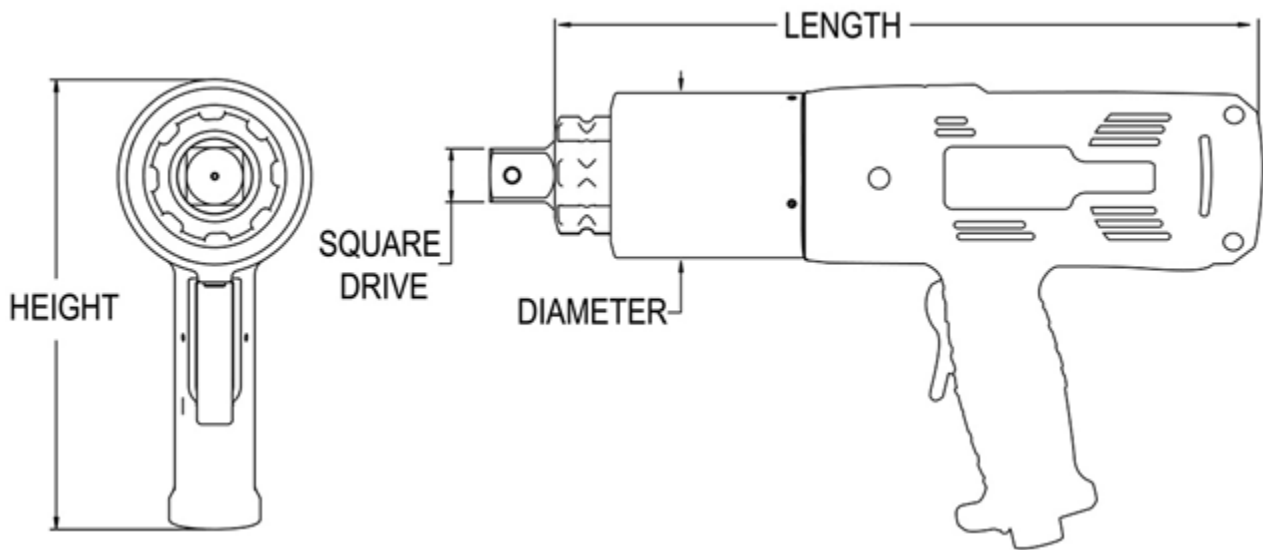

MODEL NUMBER	SR-500	SR-1000	SR-2000	SR-3000	SR-600
Height	9.29" / 236.0mm	9.29" / 236.0mm	9.29" / 236.0mm	9.31" / 236.5mm	9.94" / 252.5mm
Square Drive	0.75"	1"	1"	1"	1.5"
Length	11.45" / 290.8mm	13.23" / 336.0mm	13.94" / 354.1mm	16.18" / 411.0mm	16.88" / 428.8mm
Diameter	2.56" / 65.0mm	2.85" / 72.4mm	3.09" / 78.5mm	3.75" / 95.3mm	5.00" / 127.0mm

ACCESSORIES



USB Port

This allows for simple installation of software updates. It can also be used to extract data effortlessly to other devices.

Touch Screen Control

The SR Series Control Box comes with a 7.5" Display with 640 x 480 Pixels and 512KB memory. It includes multiple operation modes, data logging and field calibration. It displays in both metric and imperial units.



MANUAL TORQUE MULTIPLIERS



Availability

On Site Service | Sales | Rental

Overview

Designed for providing high tightening also in confined area, with safety protection against overloads: output square drive and pin models are calibrated to break if overloaded the 20%, in order to protect the inside mechanisms. Tighten force are transmitted easily with the maximum accuracy. Gears are manufactured with high precision and high-quality steel. Accuracy $\pm 5\%$. Several models are available covering an output torque range from 1680 to 47500 Nm.

Ratio

6:1 – 26:1

Torque Range

280 – 9500 Nm

Weigh

4.9 – 30.0 kg

DATA SHEET

Model	Ratio	Max	Min	Drive	Anti wind-up	Length	Diameter	Weight
TN14	6:1	280	1680	1/2 - 3/4"		128	100	4,9
TN27	5,4:1	500	2700	3/4-1"		201	100	6,34
TN35	4,5:1	770	3500	3/4-1"		264	108	7,3
TN40	20:1	225	4500	1/2-1 1/2"	X	312	120	8,3
TN60	26:1	230	6000	1/2-1 1/2"	X	328	130	15,7
TN95	26:1	365	9500	1/2-1 1/2"	X	505	184	30,3



HYDRAULIC TENSIONERS

PST TENSIONERS



Availability

On Site Service | Sales | Rental

Overview

The standard tensioners are designed to provide a wide range of flexibility, covering stud sizes from 3/4" to 5.3/4" (M20 to M150). Different stud sizes are accommodated by the same load cell simply changing the adaptor kit consisting of Threaded Puller, Bridge and Nut Driver.

These tensioners operate at a maximum pressure of 1500bar and are made by high strength alloy steel parts for long lasting trouble free performance. Several types of tensioners are available upon request: special application design, windmill or subsea applications etc.

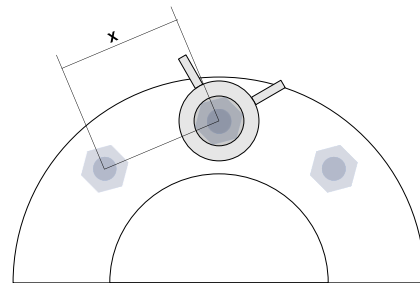
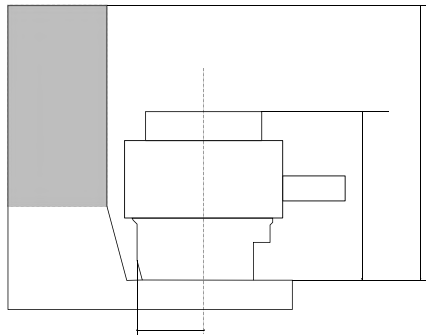

DATA SHEET AND DIMENSIONS

MODEL	KIT	BOLT DIAMETER		MAXIMUM LOAD		PULL AREA		DIAM. EXT.	X	C	A	B	WEIGHT
Cell	Adapter	inch	mm	M ton	kN	in ²	mm ²	mm	mm	mm	mm	mm	kg
PST-01	A1-0.12	3/4							46	26	86	160	3.5
	A1-M20		20						47	26	86	160	1.3
	A1-0.14	7/8		34.5	339	3.5	2257	84	53	30	94	168	1.4
PST-02	A1-M24		24						54	30	94	168	1.4
	A1-1.00	1							55	30	94	168	1.4
	A2-M27		27						56	29	96	170	4.5
	A2-1.02	1.1/8							59	32	97	171	1.8
	A2-M30		30						62	32	97	171	1.9



	A2-1.04	1.1/4		40.6	397	4.11	2649	98	67	35	99	177	2
	A2-M33		33						68	35	99	180	2.1
	A2-1.06	1.3/8							72	38	101	183	2.3
	A2-M36		36						73	38	101	186	2.3
PST-03	A3-1.04	1.1/4							69	37	99	185	5.9
	A3-M33		33						70	37	99	174	2.4
	A3-1.06	1.3/8		65.2	639	6.6	4259	115	74	40	101	176	2.9
	A3-M36		36						75	40	101	176	2.9
	A3-1.08	1.1/2							80	43	105	182	3
	A3-M39		39						80	43	105	183	3
PST-04	A4-1.06	1.3/8							75	41	101	183	7.7
	A4-M36		36						76	41	101	183	3.4
	A4-1.08	1.1/2							81	43	105	183	3.6
	A4-M39		39	73.6	721	7.45	4808	128	81	43	105	183	3.6
	A4-1.10	1.5/8							86	46	107	186	3.9
	A4-M42		42						86	46	107	186	3.9
PST-05	A4-1.12	1.3/4							91	49	108	189	4
	A5-1.10	1.5/8							87	47	132	197	11.4
	A5-M42		42						87	47	134	199	5.2
	A5-1.12	1.3/4							92	50	139	204	5.4
	A5-M45	1.3/8	45	96.1	942	9.73	6280	145	93	50	140	205	5.4
	A5-1.14	1.7/8							98	53	146	211	5.6
	A5-M48		48						98	53	146	211	5.6
	A5-2.00	2							104	56	151	216	6.3
PST-06	A5-M52		52						105	56	151	216	5.9
	A6-1.14	1.7/8							99	54	109	209	14.8
	A6-M48		48						99	54	109	209	7.1
	A6-2.00	2		138.2	1354	13.99	9028	165	105	57	112	214	7.6
	A6-M52		52			52			106	57	112	214	7.6
	A6-M56		56			56			113	61	116	223	7.8
PST-07	A6-2.04	2.1/4							114	61	116	244	7.8
	A7-M56		56						112	59	154	219	18.1
	A7-2.04	2.1/4							112	59	156	221	9.3
	A7-M60		60						117	61	163	228	9.4
	A7-2.08	2.1/2		168.5	1651	17.06	11006	180	125	66	169	231	9.7
	A7-M64		64						125	66	169	231	9.7
PST-08	A7-M68		68						129	66	177	238	10
	A8-2.08	2.1/2							129	70	137	242	23.4
	A8-M64		64						129	70	137	242	12.1
	A8-M68		68	201.8	1978	20.44	13188	198	132	69	142	246	12.3
	A8-2.12	2.3/4							139	75	142	246	12.5
PST-09	A8-M72		72						141	75	145	251	12.5
	A9-2.12	2.3/4							139	75	145	261	29.3
	A9-M72		72	230.3	2257	23.3	15045	215	141	75	145	261	15.6
	A9-M76		76						150	80	145	254	17.2
PST-10	A9-3.00	3							150	80	145	254	17.2
	A10-M80		80						160	87	156	275	40.3
	A10-3.04	3.1/4							162	87	156	278	24
	A10-M85		85						164	87	158	269	24.5
	A10-3.08	3.1/2							174	93	162	276	22.6
	A10-M90		90	310.9	3047	31.48	20312	244	175	93	154	269	22.6
	A10-M95		95						179	93	160	275	22.8



	A10-3.12	3.3/4							191	105	160	276	22.9
	A10-4.00	4							197	105	167	288	22.1
	A11-3.12	3.3/4							192	106	172	299	52.7
	A11-M100	100					196		106	179	306	31.4	
	A11-4.00	4							198	106	179	299	31.4
	A11-4.04	4.1/4							209	111	186	306	36.4
PST-11	A11-M110	110	384.5	3768	38.94	25120	280	210	111	186	308	36.4	
	A11-4.08	4.1/2							222	118	191	319	39.7
	A11-M120	120						226	118	198	327	41.4	
	A11-4.12	4.3/4							229	121	202	337	42.3
	A11-M125	125						233	121	202	212	43.3	
	A12-M125	125						236	124	204	346	89.6	
	A12-5.00	5							243	129	204	350	60.3
	A12-M130	130						243	126	207	359	63.1	
PST-12	A12-5.04	5.1/4							254	135	210	367	63.1
	A12-5.08	5.1/2		485.1	4754	49.13	31694	325	266	141	217	374	70.4
	A12-M140	140						260	135	217	374	70.6	
	A12-5.3/4	5.3/4							276	145	218	383	70.8

SPECIAL TENSIONERS



CST TENSIONERS

Overview

These tensioners are designed to operate in low clearance condition.



TSS TENSIONERS

Overview

This hydraulic tensioner has been designed to perform sub-sea operation.



CAT TENSIONERS

Overview

These 1500 bar working pressure tensioners are specially developed from our Compact series to meet auto retract and ease of operation requirement of wind mill application



DA TENSIONERS

Overview

These tensioners are specially designed for Base Bolt applications of Wind Mill Towers. customised sizes are available.

POWERPACKS





ELECTRIC PUMP



PNEUMATIC PUMP



MANUAL PUMP

SPARE PARTS



CELL



NUT DRIVER



BRIDGE



NUT DRIVER



HELIOS-35

A MAGNETIC INDUCTION HEATING UNIT FOR TIGHTENING AND LOOSENING HOLLOW BOLTS, TIE RODS, NUTS AND MORE.

Power	25 KVA
Frequency range	5 ÷ 35 KHz
Supply	400V AC-3ph-50Hz (60Hz on request)
Electrical plug	32A 3P+E
Weight	205 Kg
Dimensions	1000 x 830 x H 1000mm



Power and efficiency.

The heating power of the previous versions of our magnetic induction machines was considerable and allowed to heat tie rods reducing overall process time by 80%. An outstanding result considering how slow and risky the old and obsolete resistance/free flame heating methods were. Helios-35 exceeds the previous versions, not only in terms of power and prompt heating, but also in terms of efficiency. Among the optional features, there is the possibility of enabling a timer to set the heating time, and a color display to facilitate the operations during consecutive loosening processes.

All-in-one.

Differently from other bolt induction heating machines, Helios-35 is all-in-one. Apart from being really compact in dimensions, it doesn't need huge external cooling chillers to make it work. It simply relies on an internal cooling

User-friendly and upgradable operating system.

It doesn't matter if you are using linear or ring-shaped inductors. Setting the operating parameters is a breeze. Thanks to the new graphic colour display, the setting procedures are guided and easy-to-read so that the functions of the machine can be easily managed.

Training for the operators.

We provide specific training courses to explain extensively the system and make the most out of the potential of our bolt induction heating machines. The training course is held only by one of our specialized technicians independently of location.

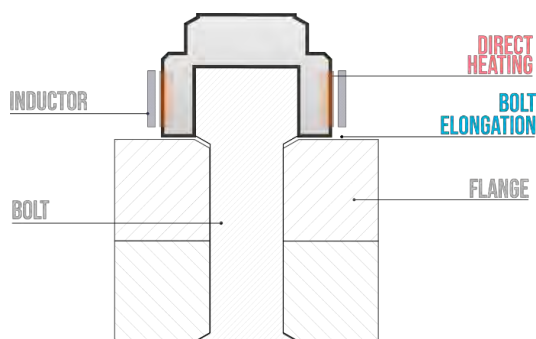

RSI directly heat up stucked nuts

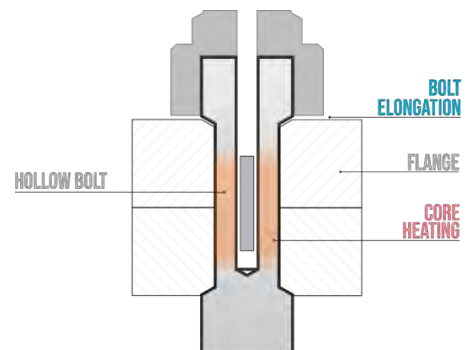

Axial inductors heat up the core of hollow bolts



IMPACT WRENCHES

PNEUMATIC IMPACT WRENCHES

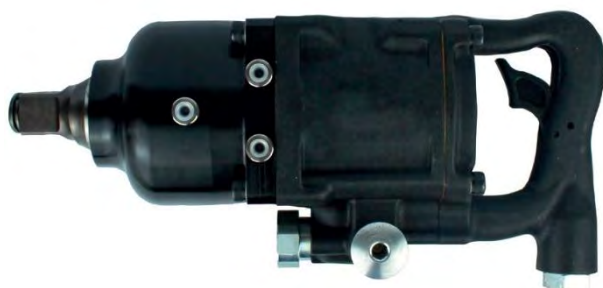

Availability

On-Site Service | Sales | Rental

Overview

Durability, ergonomics, lightness. These impact wrenches are produced using material from the aviation and military industry such as special steels, carbon fiber, aluminum and magnesium alloy, titanium. When performance is what you are looking for, Light Duty or Heavy-Duty Impact Wrenches are at your disposal.

ATEX available

Bolt Range

M5 – M110

Square Drive

3/8" – 2-1/2"

Working Torque Range

26 – 8.790 Nm

HYDRAULIC IMPACT WRENCHES



Availability

On-Site Service | Sales | Rental

Overview

Hydraulic impact wrenches are equipped with an economic and ecological system: you consume energy only when you use the impact wrench. The hydraulic mechanism also allows torque repeatability and higher torque compared to pneumatic models of equal weight. Essential for outdoor support operations, they are fitted to be used in construction sites, mobile workshops, infrastructures maintenance and roadside assistance. Paoli hydraulic systems are perfect also for tire specialists, repair shops and situations where all the air supplies are already being used by other tools.

ATEX: available

Bolt Range

M14 – M36

Working Torque Range

4300 Nm



DATA SHEET

Model	Ratio
Weight	60 kg - 132 lbs,
Power	2.2 Kw,
Tension	220/400 v trifase - 50/60 Hz,
Square drive	DPH EVO 340 - DPH EVO 340 AL 3/4" DPH EVO 341 - DPH EVO 341 AL 1"
Bolt range	DPH EVO 340 - DPH EVO 340 AL M14-M24
Ultimate torque	
Free speed	3000 Nm - 2220 ft-lb
Max oil flow	2800 rpm
Length (without anvil)	10 l/min
Side to center	253 mm - 9.96 in

ACCESSORIES



SOCKETS



Availability

Sales | Rental

Overview

Standard, deep and thin-wall sockets up to 3-1/2" square drive. Hexagon and bi-hexagon impact sockets up to 235mm (9-1/8") A/F. Wide variety of Accessories. All impact sockets are made from high strength alloy steel and are heat treated for the best combination of strength and impact resistance. Customizable solutions on request.

Bolt Range

M14 – M36

Working Torque Range

4300 Nm



Ask us for a more detailed Impact Socket Catalogue.

marketing@nuovasimat.com



BACK UP WRENCH



Availability

Sales | Rental

Overview

Stop the opposing nuts from turning during bolting procedures! Improved durability (aircraft quality steel construction, totally mechanical, simple to release). Standard imperial and metric sizes available, covering from 19 to 105mm A/F. Evaluate custom designs to fit your applications

